

Thermocouples

Surface Temperature Measurement

Radio Frequency Thermocouple Probe (TR)

Watlow's TR thermocouple probe is designed for use in plasma generation. Radio frequency energy can cause serious temperature measurement errors through radiation or conduction. Traditional sensors are ineffective against the induced noise associated with such environments. The TR probe is ideal for reading temperatures through such interference.

The construction of the TR probe utilizes a unique combination of high performance materials. The sensor tip is made from high thermal conductivity materials, providing a quick response time. High dielectric insulation is used to electrically insulate the sensor from capacitive coupling. Additionally, the lead wires are twisted to improve common mode rejection and reduce induced EMI.

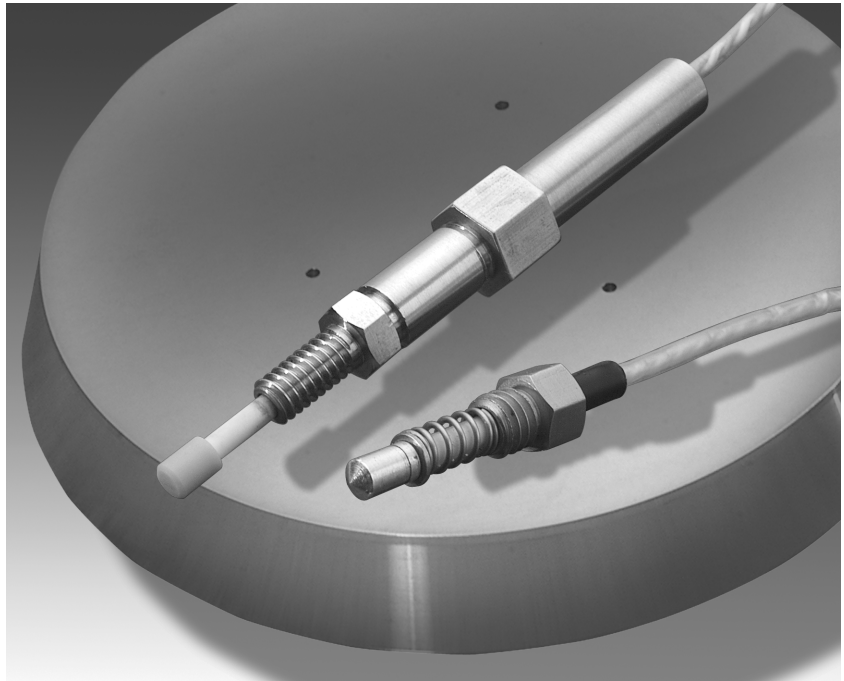

Options

- Type E, J or K calibration
- Drill point or flat tip designs
- 0.875 inch (22.23 mm) to 1.5 inch (38.10 mm) immersion depths
- $\frac{5}{16}$ - 18 or M8 threaded fitting

Features and Benefits

3000V $\overline{\text{dc}}$ dielectric rating

- Allows thermocouple to be used in platens with dc bias

High thermal conductivity design

- Ensures accurate, repeatable measurements

High CMMR lead wire design

- Reduces induced error from EMI

Thermocouples

Surface Temperature Measurement

TR Thermocouple

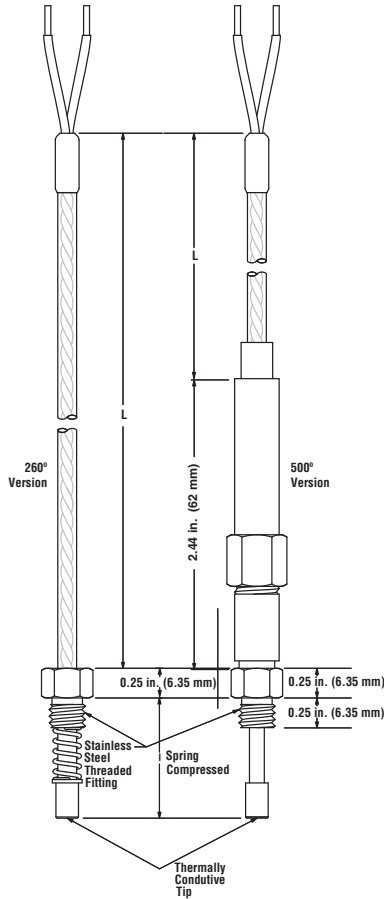

Tip Shape

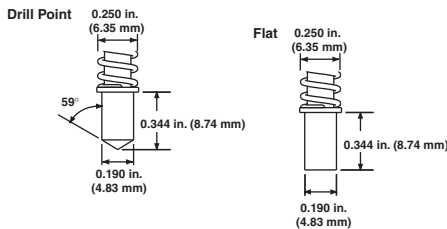

Platen Modification Detail

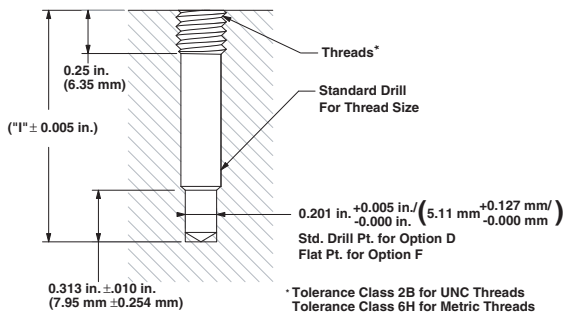

Ordering Information—To order, complete the part number on the right with the information below:

1 2 3 4 5 6 7 8 9 10 11 12
T R

TR Thermocouple

3. Maximum Temperature

- C = 260°C silver-plated copper tip
- N = 500°C aluminum nitride tip (AlN)

4. Tip Shape

- D = Drill point (260°C tip only)
- F = Flat

5-6. Immersion Depth "I" (inch)

(from tip to top of threads, spring compressed)

- 08 = 0.875
- 10 = 1.000
- 11 = 1.125
- 12 = 1.250
- 13 = 1.375
- 15 = 1.500

7. Threaded Fitting Size

- 5 = 5/16-18 UNC-2A
- 8 = M8 x 1.25-6g

8. Junction Type

- U = Ungrounded single

9. Calibration

- J = Special limits J (±1.1°C or ±0.4%)
- K = Special limits K (±1.1°C or ±0.4%)

10-11. Lead Length "L"

- XX = 01 to 96 inch

12. Lead Wire Terminations

- A = Standard male plug
- B = Standard female jack
- C = Standard plug with mating connector
- F = Miniature male plug
- G = Miniature female jack
- H = Miniature plug with mating connector
- T = Standard, 1.5 in. (38.10 mm) split leads
- U = 1.5 in. (38.10 mm) split leads with spade lugs